



*Leaving Certificate Examination, 2013*

***Design & Communication Graphics***  
***Higher Level***

***Sections B and C (180 marks)***

**Wednesday, 19 June**  
**Afternoon, 2:00 - 5:00**

**This examination is divided into three sections:**

- SECTION A (Core - Short Questions)  
SECTION B (Core - Long Questions)  
SECTION C (Applied Graphics - Long Questions)

- SECTION A**
- Four questions are presented.
  - Answer **any three** on the accompanying A3 examination paper.
  - All questions in Section A carry **20 marks** each.

- SECTION B**
- Three questions are presented.
  - Answer **any two** on drawing paper.
  - All questions in Section B carry **45 marks** each.

- SECTION C**
- Five questions are presented.
  - Answer **any two** (i.e. the options you have studied) on drawing paper.
  - All questions in Section C carry **45 marks** each.

**General Instructions:**

- *Construction lines must be shown on all solutions.*
- *Write the question number distinctly on the answer paper in Sections B and C.*
- *Work on one side of the drawing paper only.*
- *All dimensions are given in metres or millimetres.*
- *Write your Examination number in the box provided on section A and on all other sheets used.*

## SECTION B - Core

Answer **any two** questions from this section on drawing paper

**B-1.** The image below shows “*Fountain Place*”, a skyscraper in Dallas, Texas. The building was designed as a large, glass faced building, which the architect described as "what's left after carving into a square prism."

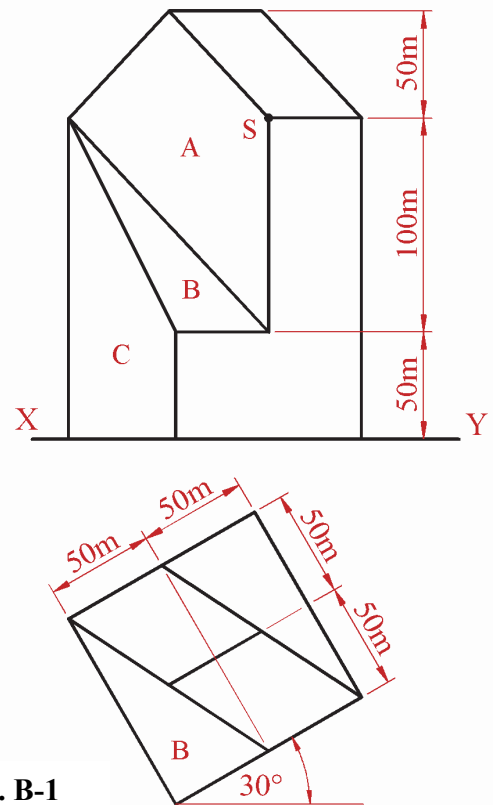

**Fig. B-1**

Fig. B-1 shows the plan and elevation (excluding hidden detail) of the structure.

- (a) Draw the given plan and elevation of the structure.
- (b) Determine the dihedral angle between the planes **A** and **B**.
- (c) Determine the true shape of the vertical surface **A**.
- (d) The director of a future *Mission Impossible* movie wants to shoot a scene that involves climbing the outside of the building. A stuntman is to travel down from point **S** along surfaces **A**, **B** and **C** to the ground.

Determine the projections of the line on each plane that the stuntman must move along so that he travels the shortest possible distance on each successive surface as shown on the right.

**Scale 1:2000**



**B-2.** Soccer is one of the most popular team sports in the world. The 3D graphic on the right shows a set of typical soccer goal posts.



Fig. B-2 shows an incomplete dimetric projection of similar goal posts using the axonometric axes method. The elevation and end view are shown in their required positions. A pictorial view of the goal posts is also shown.

(a) Draw the axonometric axes **X**, **Y** and **Z** and the isosceles triangle **abc**.

(b) Draw the elevation and end view orientated as shown and complete the axonometric projection.

(c) A ball is positioned, on the ground at a point **F**, for a kick. Point **F** is 9m away from the goal line and is located in the direction shown.



The path of the ball after it is kicked is a parabola which reaches a maximum height of 6m having travelled a horizontal distance of 6m.

By drawing the parabola in the end view, or otherwise, determine whether the ball goes under or over the crossbar.

*(Ignore the radius of the ball.)*

**Scale 1:100**

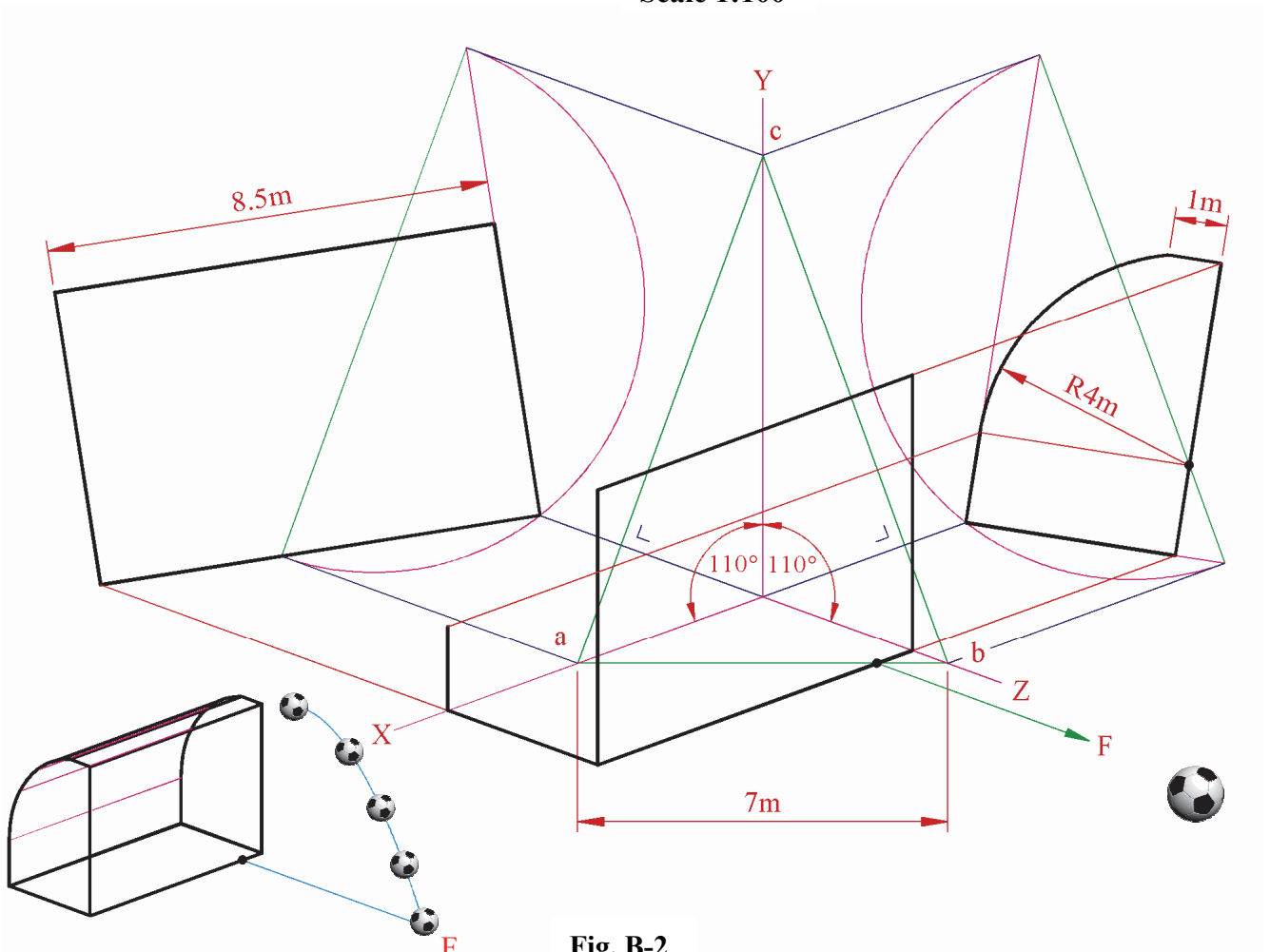

**Fig. B-2**

**B-3.** The Egyptian pyramids, shown in the 3D graphic below, are considered to be architectural masterpieces. They are square-based and were built with precision in terms of alignment, geometrical shape and proportion.

Fig. B-3 shows the plan and elevation of a square based pyramid with an intersecting triangular entrance.

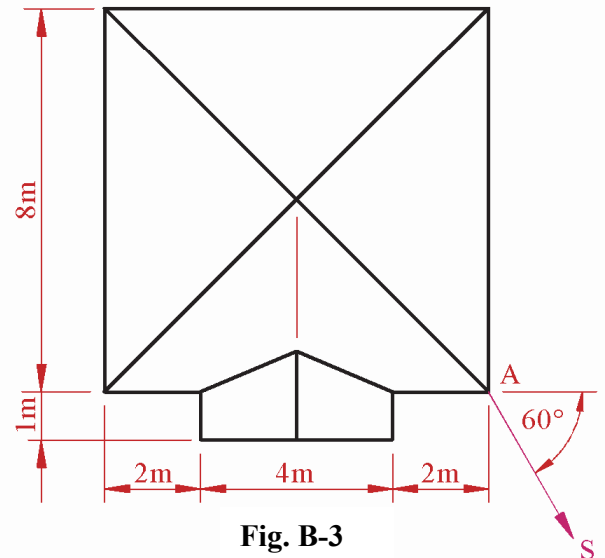
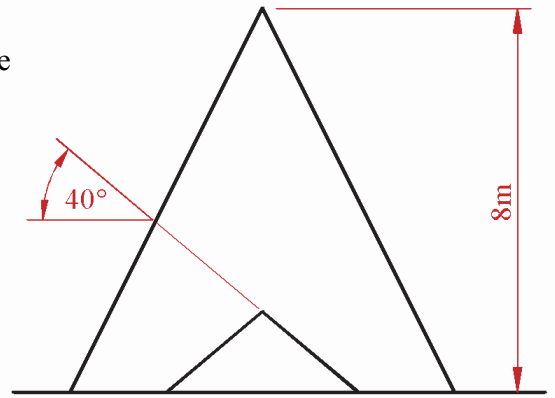

Scale 1:100

Fig. B-3

(a) Draw the given plan and elevation and construct a perspective drawing of the structure given the following:

- The spectator point is 8m from the corner A
- The picture plane is touching the corner A
- The horizon line is 5m above the ground line.

*Note: Use an auxiliary vanishing point to locate the sloping edges of the entrance.*

(b) The interior of the pyramids typically contained numerous passageways which were either level or sloping. Two such passageways are represented by the skew lines AB and CD. The horizontal and vertical coordinates of these skew lines are given below.

A	=	100	---	30	---	20
B	=	140	---	100	---	80
C	=	210	---	40	---	40
D	=	120	---	100	---	10

- On a separate diagram, draw the projections of the two skew lines, AB and CD.
- Determine, and indicate in millimetres on your drawing, the true length of the shortest connecting shaft that can be drilled between the two passageways AB and CD.

Scale 1:1

## SECTION C - Applied Graphics

Answer **any two** questions (i.e. the options you have studied) from this section on drawing paper.

### Geologic Geometry

**C-1. (a)** The accompanying map, located on the back page of Section A, shows ground contours at 5 metre vertical intervals.

**ABC** is the centreline of a proposed roadway and the line **DE** is the centreline of a proposed motorway overpass.

The roadway **ABC** has the following specification:

- (i) the section of the roadway between **A** and **B** is level at an altitude of 40m
- (ii) the section from **B** to **C** has a gradient of 1 in 10 falling.

Using side slopes of 1 in 1 for the cuttings and 1 in 1.5 for the embankments, complete the earthworks necessary to accommodate the roadway **ABC** on its northern side.

*Note: The earthworks on the southern side of the roadway have already been completed.*

**(b)** It is proposed to construct a motorway overpass, as shown in the image on the right, along the line **DE**.

In the space provided to the right of the map, draw a vertical section (profile) on the line **DE**.

The section should show the profile of the ground after the earthworks for the roadway **AB** have been completed but before the overpass **DE** has been constructed.



**(c)** On the map, points **P**, **Q** and **R** are three points on the surface of the earth. Vertical boreholes drilled at these three points are shown in elevation, in the space provided above the map. They reveal the top surface of a stratum of ore at distances of 5m, 35m and 10m below **P**, **Q** and **R**, respectively.

- (i) Draw the plan and elevation of the top surface of the stratum.
- (ii) Determine the strike and dip of the stratum.

**Scale 1:1000**

# Structural Forms

**C-2.** The graphic on the right shows an uplighter in the form of a hyperbolic paraboloid surface.



Fig. C-2 below shows the plan, elevation and end view of a similar uplighter. An isometric view is also shown.

The surface of the hyperbolic paraboloid is generated by translating the parabola **ABC** in a horizontal position downwards along the parabola **BD**.

**B** is the vertex of the parabola **ABC** and **D** is the vertex of the parabola **BD** as shown.

- (a) Draw the given plan of the uplighter.
- (b) Project the given end view from the plan.
- (c) Project the front elevation of the uplighter.
- (d) The curves in elevation form a portion of a double hyperbola whose vertices are  $V_1$  and  $V_2$  and whose focal points are located at  $F_1$  and  $F_2$ , respectively.

Determine the asymptotes to the double hyperbola in elevation.

**Scale 1:2**

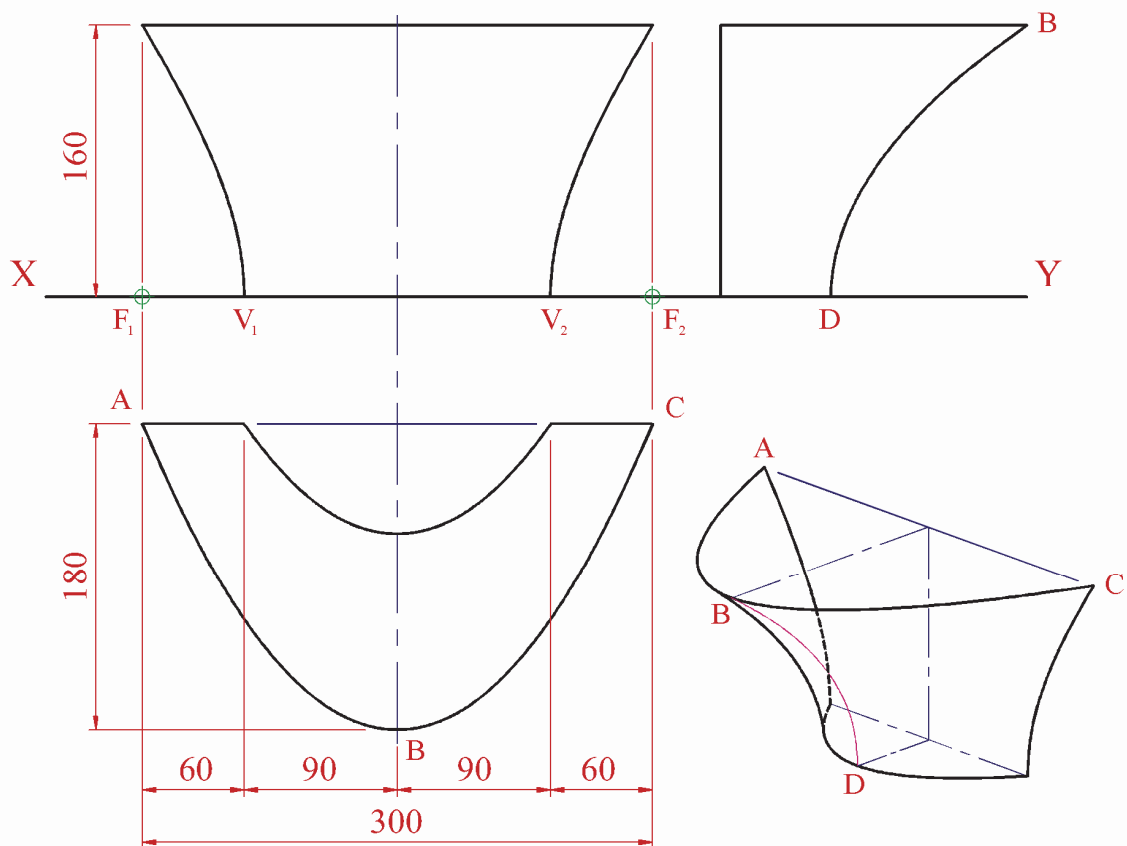

**Fig. C-2**

# Surface Geometry

**C-3.** The 3D graphic on the right shows the pop star Beyoncé and her notable engagement ring. The brilliance of the diamond is determined by the accuracy and symmetry of the geometry used in its design.



Fig. C-3 below shows the outline plan and elevation of a cut diamond. A pictorial view is also given.

- (a) (i) Draw the given plan of the diamond.
- (ii) Surfaces **A** and **C** on the top of the diamond have a pitch of  $45^\circ$ . Draw the elevation of the top portion of the diamond (surfaces **B**, **C** and **E**).
- (b) Determine the dihedral angle between the surfaces **A** and **B**.
- (c) All the sloping edges on the underside of the diamond have a true length of 9.5mm (95mm when scaled). Complete the elevation of the diamond as shown.
- (d) Determine the dihedral angle between the surfaces **D** and **F**.

**Scale 10:1 (Enlarged scale)**

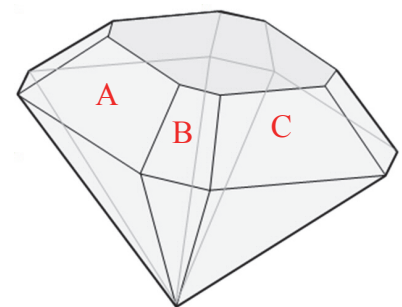
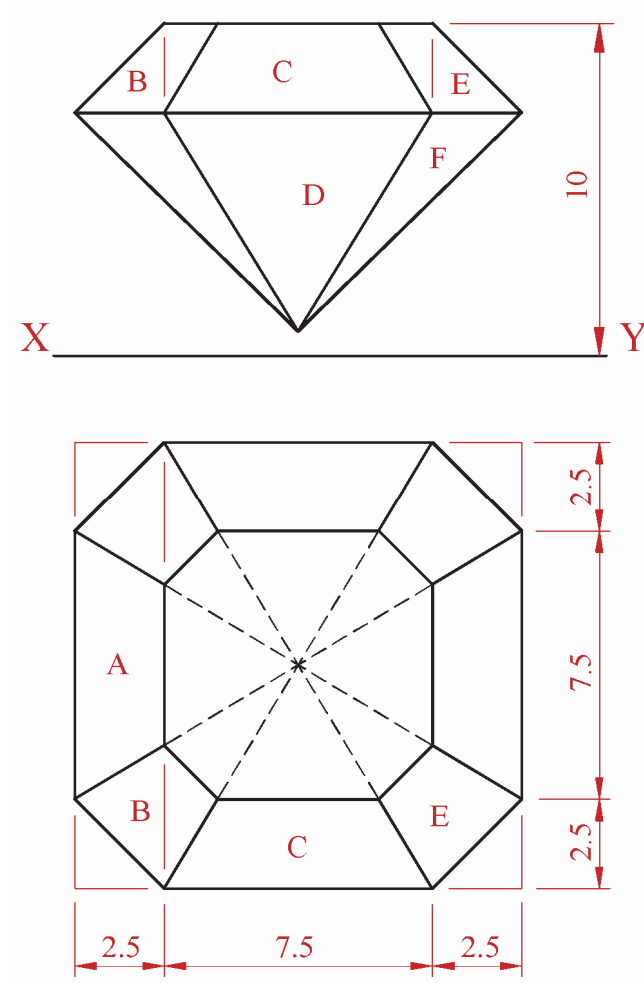

**Fig. C-3**

# Dynamic Mechanisms

**C-4. (a)** The 3D graphic on the right shows a machine for baling recyclable cardboard.

A link mechanism in the machine is similar to the one shown in line diagram format in Fig. C-4(a) below.

Crank **OA**, starts in the given position and rotates at a constant speed in an anti-clockwise direction through  $360^\circ$  about point **O**. Crank **OA** is pin jointed to the arm **BC** at its midpoint **A**, as shown.

End **B** is constrained to travel along the horizontal centre line.

Arm **CD** is pin-jointed at **C** and always hangs in a vertical position.

Plot the locus of point **D** for the movement.

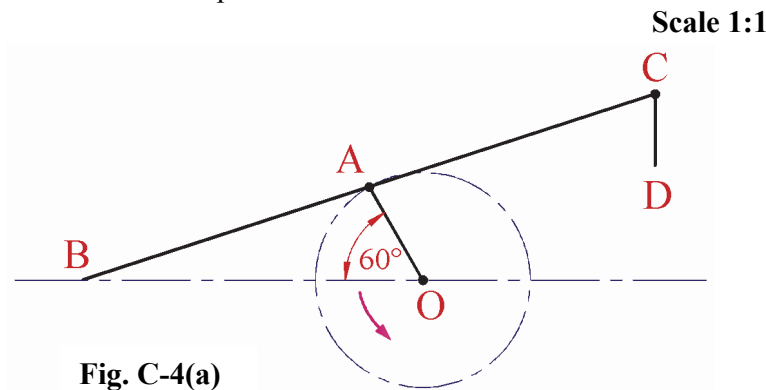

**Arm/Crank Lengths**

- OA = 30
- BC = 168
- CD = 20

**(b)** The 3D graphic on the right shows a radial plate cam, which is located inside the baling machine. A 2D drawing of the cam is also shown in Fig. C-4 (b) below.

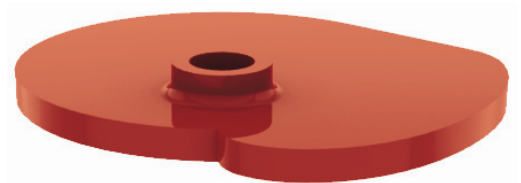

The inner minimum diameter circle has a radius of 18mm. The portion of the cam profile from **A** to **B** is an involute to this circle.

The cam rotates in an anti-clockwise direction and has an inline knife edge follower. The camshaft, which is hatched in the diagram, has a diameter of 16mm.

- (i) Draw the given cam profile and plot the displacement diagram for one full rotation.  
(In the displacement diagram, use a distance of 15mm to represent each  $30^\circ$  interval.)
- (ii) On your drawing, determine and indicate in millimetres, the maximum displacement distance.

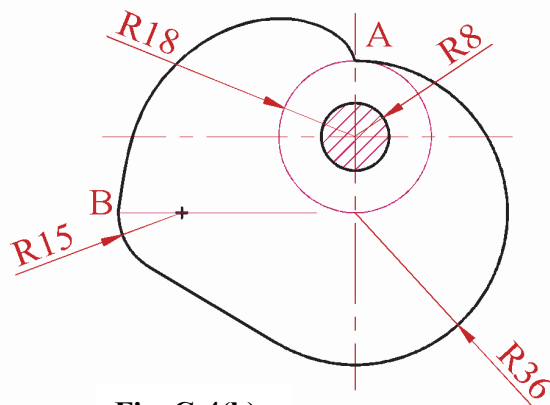



# Assemblies

**C-5. (a)** Details of a Wall Mounted Candle Lantern are shown in Fig. C-5. The lantern is fitted with a device to raise the candle for ease of lighting.

Draw a full size sectional elevation on A-A, showing the parts fully assembled with the height adjustment lever (part 3) in the horizontal position and the candle platform (part 6) in the fully lowered position.

*(Unless otherwise stated, all fillets are 6mm, all chamfers are 1 x 45° and any omitted dimensions may be estimated).*

**(b)** Determine and indicate in millimetres on your drawing the maximum height travel of the platform when it is raised by the height adjustment lever.

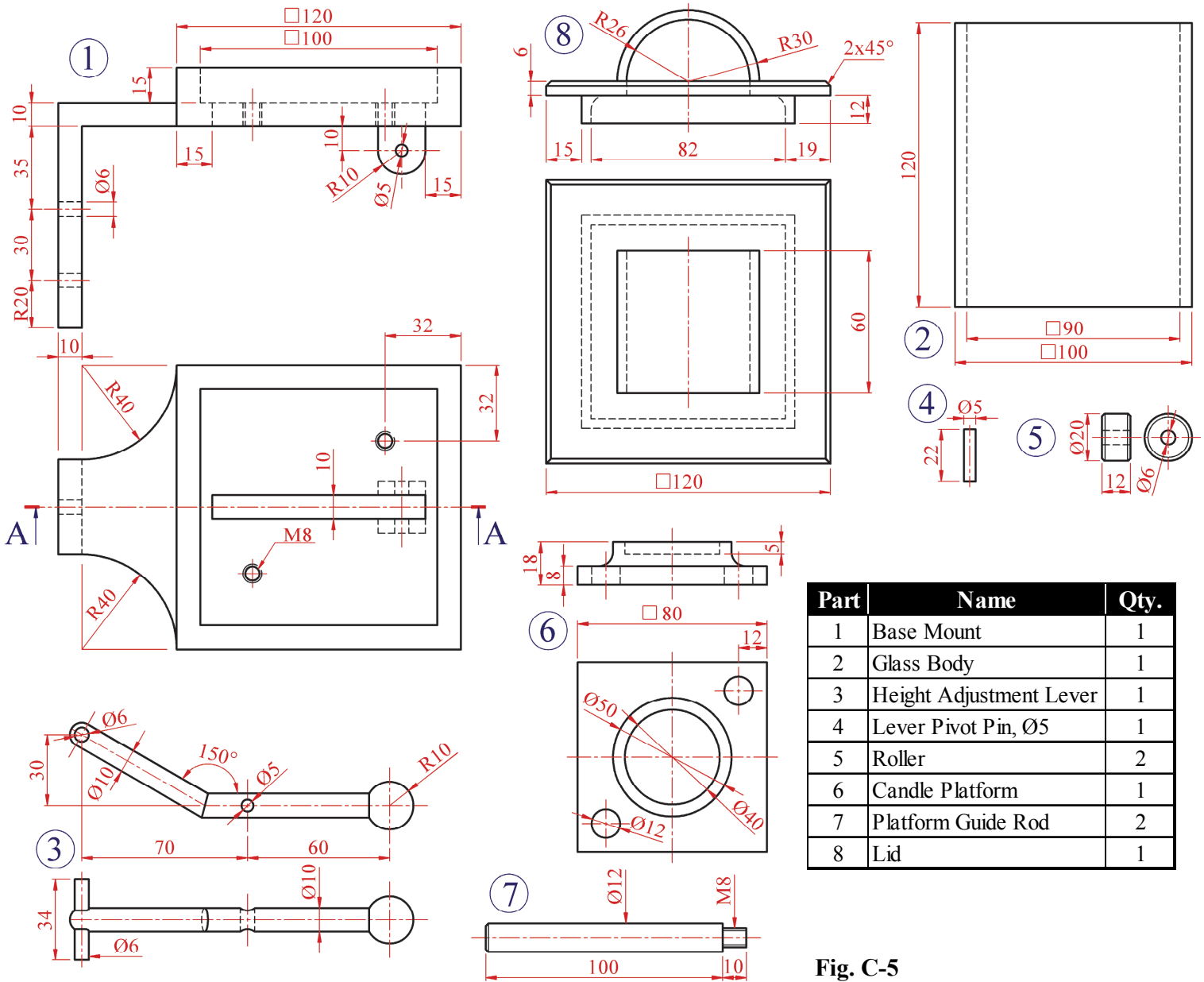

**Fig. C-5**

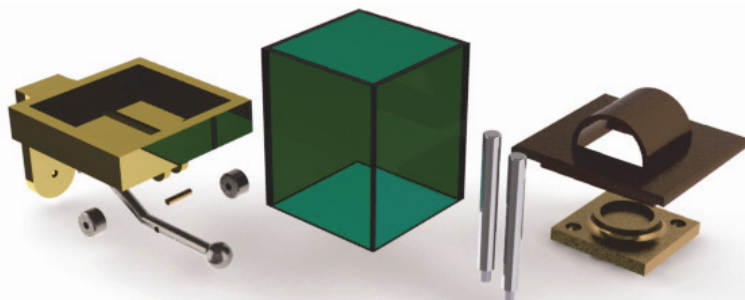

**BLANK PAGE**

**BLANK PAGE**

**BLANK PAGE**